

soft top jaws

AWB-D low/tipped version

INCH serration
1/16" x 90°

Material: 16MnCr5
serration ground

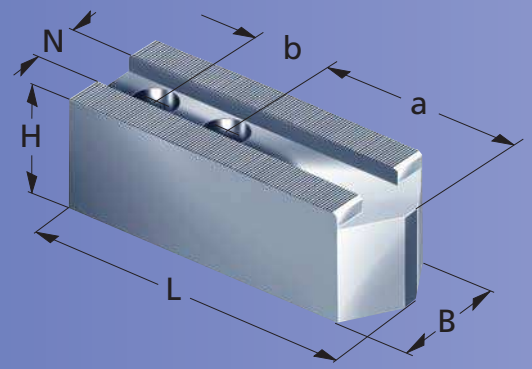

Type	Id.-No.	B	H	L	N	serration	a + b for DIN 912	kg/set	SMW-AUTOBLOK	SMW	Autoblok
AWB-D 110	038258	20	20	55	8	1/16" x 90°	30 + 12 M6	0,55	HFKN-D 110	HFKS 110-26	
AWB-D 165	035954	40	40	80	14	1/16" x 90°	43 + 22 M10	2,0	HFKN-D 165 SP/STP 160 AN/AL/BH/HB-D 165* BHD-FC 165* PB/PBI/RC-D 165* AP/NT-D 170* BB-D 175* HYND-S 180*	SP 160 STP 160	GHD-FC 165 GHDN 165
AWB-D 160	081614	40	40	80	17	1/16" x 90°	43 + 22 M12	2,0	HFKN-D 210 SP/STP 200/240 AN/AL/BH/BB-D 210 BHD-FC 210 CC 240Z HB/PB/PBI/RC-D 210 AP/APL/NT-D 215 AP/APL/NT-D 260* HYND-S 210/226	KDV 160/200/250 KDBG 160/200/250 KFV 160/200 HFK/HFKS 160/200 KFMF 160/200	ODL 200 ODN 200/220 HDL 200 HDN 200/220 GHD/FC 210 GHDN 210 HDB 220 CD 200 210 RCD
AWB-D 200	081616	40	40	90	17	1/16" x 90°	53 + 22 M12	2,7	HFKN-D 210 SP/STP 200/240 AN/AL/BH/BB-D 210 BHD-FC 210 CC 240Z HB/ PB/PBI/RC-D 210 AP/APL/NT-D 215 AP/APL/NT-D 260* HYND-S 210/226	KDV 200/250 KDBG 200/250 KFV 200 HFK/HFKS 160/200 KFMF 200	ODL 200 ODN 200/220/250 S HDL 200 HDN 200/220/250 S GHD/FC 210 GHDN 210 HDB 220 CD 200 210 RCD
AWB-D 250	081618	50	50	120	21	1/16" x 90°	70 + 28 M16	5,3	HFKN-D 260/315 SP/STP 280 SP/SP-L 350 AN/AL/BH/BB-D 250* AN/AL/BH/BB-D 315* BHD-FC 250/315* RC-D 250/305/400* CC 350Z HB/PB/PBI-D 250/315* AP/APL/NT-D 315* HYND-S 250/315*	KDV 315/400 KDBG 315/400 KFV 250/315 HFK/HFKS 250/270/315 KFMF 250/315 SP/STP/STWP 250 SP/STP/STWP 315 LP 250	ODL 250/315/400 ODN 250/315/400 HDL 250/315/400 HDN 200/315/400 GHD/FC 250/305/400 GHDN 250/315/400 HDB 300 CD 250/315-65/315-85 250 RCD 305 RCD
AWB-D 315	081619	50	50	140	21	1/16" x 90°	90 + 28 M16	9,4	HFKN-D 260/315 SP/STP 280 SP/SP-L 350 AN/AL/BH/BB-D 315* BHD-FC 315* RC-D 305/400* CC 350Z HB/PB/PBI-D 315* AP/APL/NT-D 315* HYND-S 315*	KDV 315/400 KDBG 315/400 KFV 315 HFK/HFKS 270/315 KFMF 315	ODL 315/400 ODN 315/400 HDL 315/400 HDN 315/400 GHD/FC 305/400 GHDN 315/400 HDB 300 CD 315-65/315-85 305 RCD

* with single T-nuts only



Page 6



Page 24
Page 35
Page 143
Page 144

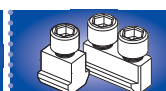

Page 55



Page 66