

soft pie jaws

SBS-D

INCH serration
1/16" x 90° or 3/32" x 90°

Material: 16MnCr5
serration ground

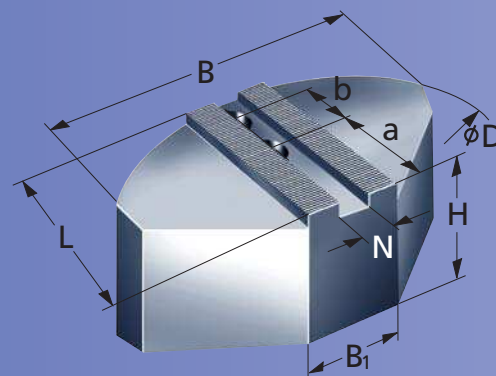

Type	Id.-No.	B	B ₁	H	L	D	N	serration	a + b for DIN 912	kg/set	SMW-AUTOBLOK	SMW	Autoblok
SBS-D 165	035154	120	40	60	60	160	14	1/16" x 90°	25 + 22 M10	5,6	HFKN-D 165 SP/STP160 AN/AL/BH/HB-D 165* BHD-FC 165* PB/PBI/RC-D 165* AP/NT-D 170* BB-D 175* HYND-S 180*	SP 160 STP 160	GHD-FC 165 GHDN 165
SBS-D 160	081639	120	40	60	60	160	17	1/16" x 90°	25 + 22 M12	5,6	HFKN-D 210 SP/STP 200/240 AN/AL/BH/BB-D 210 BHD-FC 210 CC 240Z HB/PB/PBI/RC-D 210 AP/APL/NT-D 215 AP/APL/NT-D 260* HYND-S 210/226	KDV 160/200/250 KDBG 160/200/250 KFV 160/200 HFK/HFKS 160/200 KFMF 160/200	ODL 200 ODN 200/220 HDL 200 HDN 200/220 GHD/FC 210 GHDN 210 HDB 220 CD 200 210 RCD
SBS-D 200	081640	140	60	60	70	200	17	1/16" x 90°	35 + 22 M12	8,3	HFKN-D 210 SP/STP 200/240 AN/AL/BH/BB-D 210 BHD-FC 210 CC 240Z HB/PB/PBI/RC-D 210 AP/APL/NT-D 215 AP/APL/NT-D 260* HYND-S 210/226	KDV 200/250 KDBG 200/250 KFV 200 HFK/HFKS 160/200 KFMF 200	ODL 200 ODN 200/220/250 S HDL 200 HDN 200/220/250 S GHD/FC 210 GHDN 210 HDB 220 CD 200 210 RCD
SBS-D 250/21	081642	180	100	70	80	250	21	1/16" x 90°	35 + 28 M16	13,6	HFKN-D 260/315 SP/STP 280 SP/SP-L 350 AN/AL/BH/BB-D 250* AN/AL/BH/BB-D 315* BHD-FC 250/315* RC-D 250/305/400* CC 350Z HB/PB/PBI-D 250/315* AP/APL/NT-D 315* HYND-S 250/315*	KDV 315/400 KDBG 315/400 KFV 250/315 HFK/HFKS 250/270/315 KFMF 250/315 SP/STP/STWP 250 SP/STP/STWP 315 LP 250	ODL 250/315/400 ODN 250/315/400 HDL 250/315/400 HDN 200/315/400 GHD/FC 250/305/400 GHDN 250/315/400 HDB 300 CD 250/315-65/315-85 250 RCD 305 RCD
SBS-D 400	133459	330	150	85	155	440	25,5	3/32" x 90°	85 + 35 M20	55,0	AP/AP-L/NT-D 400* BB-N 400/460/500/600 BB-N ES 400/460/500/600 BB-AZ-ES 500 AN/AL/BB-D 400 BH-D 400/450/500/630/800 BHD-FC 400/500/630 IN/L-D 500/630/800 HYD-S 400/500 HYDL-S 400/500/550/630/800 HYDLL-S 550/630	KDBG 500 KFV 400/500/630/800 HFK/HFKS 400/500	

* with single T-nuts only



Page 6



Page 24

Page 35

Page 143

Page 144

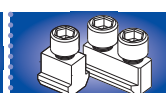

Page 55



Page 66