

soft top jaws for front end power chucks

INCH serration
1/16" x 90° or 3/32" x 90°

Material: 16MnCr5/1C45

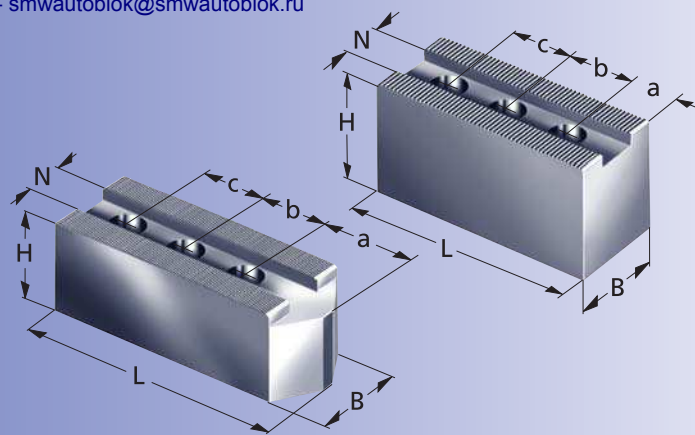

Type	Id.-No.	B	H	L	N	serration	a + b + c for DIN 912	kg/ set	SMW- AUTOBLOK	SMW	Röhm	Schunk
WBC-D 125*	013795	30	40	74	11	1/16" x 90°	35 + 18 M 8	1,6		SP 125-26 STP 125 STWP 125	LVE 125	TP 125-26 ROTA TP 125
MWB-D 130	013488	30	40	55	12	1/16" x 90°	29 + 16 M 8	1,2	SP 125 ab Bj. 98 STP 125			
WBSA-D 125*	12071300	30	60	12				0,9				
AWB-D 165*	035954	40	40	80	14	1/16" x 90°	43 + 22 M 10	2,0	SP 160 ab Bj. 98 STP 160	SP 160-38 STP 160 STWP 160	LVE 160	TP 160-38 ROTA TP 160
AWB-D 200*	081616	40	40	90	17	1/16" x 90°	53 + 22 M 12	2,7	SP 200/240 STP 200/240 CC 240 Z	SP 200-52 LP 205 • STP 200 STWP 200	LVE 200	TP 200-52 ROTA TP 200
AWB-D 250*	081618	50	50	120	21	1/16" x 90°	70 + 28 M 16	8,2	SP 250/280/350 SP 280 STP 280	SP 250-68 • LP 250 STP 250 • STWP 250 SP 315-105 • SP 315-90 STP 315-105 STWP 315-105	LVE 250 LVE 315	TP 250/315 ROTA TP 250/315/350
AWB-D 315*	081619	50	50	140	21	1/16" x 90°	90 + 28 M 16	9,4	SP 350 SP-L 350 CC 350 Z			TP 315 ROTA TP 315/350
WBC-D 400	013787	60	80	158	25,5	3/32" x 90°	81 + 40 M 18	16,5		BB 400 • LP 380 LP 460 • BB 400 ES STP 400	LVE 400/500	TB 400 ROTA EP 380 ROTA TB 400
WBC-D 500	013789	60	80	185	25,5	3/32" x 90°	108 + 40 M 18	19,5		BB 500 LP 500 BB 500 ES BB 630-265 ES STP 500	LVE 630/800 LVE 1000	TB 500 ROTA EP 460 ROTA TB 500/610 ROTA TB 630-265 LH
WBSA-D 500*	12075050	60	60	170	25,5	3/32" x 90°	25 + 38 + 38 M 20	13,5	BB-N 400/460/500/600 BB-N ES 400/460/500/600			
WBC-D 502*	12075140	60	60	205	25,5	3/32" x 90°	104 + 38 + 38 M 20	16,5	BB-N 400/460/500 BB-N ES 400/460/500/600			
WBC-D 630*	12076440	80	80	240	30	3/32" x 90°	30 + 50 + 50 M 24	33,0	BB-N 630 BB-N ES 630	BB 630 STP 630 BB 630-325 ES		ROTA TB 630 TB 800/1000/1200 ROTA TB 800/850/100/1200
WBC-D 800*	12078040	80	80	320	30	3/32" x 90°	165 + 60 + 60 M 24	45,0	BB-N 800 BB-N 1000 BB-N ES 850/1000	BB 800 • BB 850 ES BB 1000 BB 1000 ES • STP 800		TB 800/1000/1200 ROTA TB 800/850/100/1200
WBCL-D 800*	12079040	80	80	390	30	3/32" x 90°	230 + 60 + 60 M 24	54,0	BB-N 800 BB-N 1000 BB-N ES 850/1000			TB 800/1000/1200 ROTA TB 800/850/100/1200

*jaws tipped



Page 6



Page 24
Page 35
Page 143
Page 144

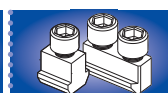

Page 55

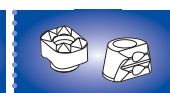

Page 66

smwautoblok@smwautoblok.ru
www.smwautoblok.ru