

soft special jaws on customer request

soft top jaw-blanks

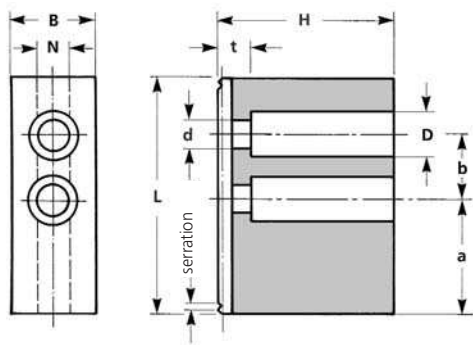

- a
- b
- B
- d
- D
- H
- L
- N
- t
- serration
(e.g. 1/16"x90°)
- material

soft top jaw-blanks

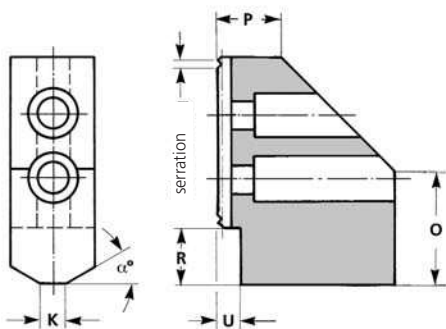

- K
- O
- P
- R
- U
- α°

soft top jaws for external clamping

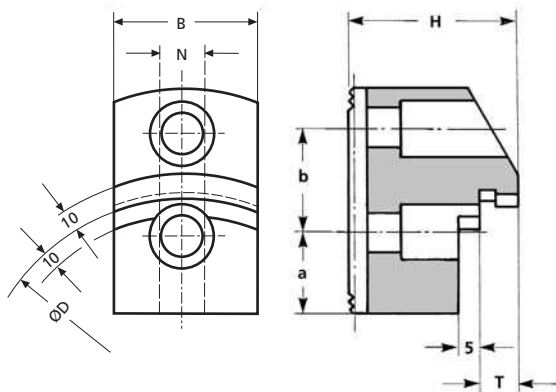

- B
- H
- T
- D
- N
- a
- b
- serration
(e.g. 1,5 x 60°)
- work-piece \emptyset
- chuck maker
- chuck type
- material

soft top jaws for internal clamping

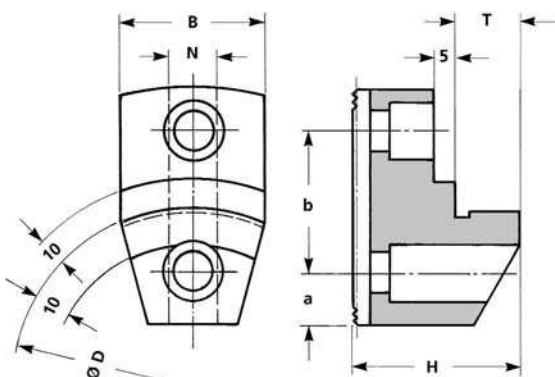

- B
- H
- T
- D
- N
- a
- b
- serration
(e.g. 1,5 x 60°)
- work-piece \emptyset
- chuck maker
- chuck type
- material