

hard roughing jaws

GG-D

for external- and internal clamping

INCH serration
1/16" x 90° or 3/32" x 90°

serration ground

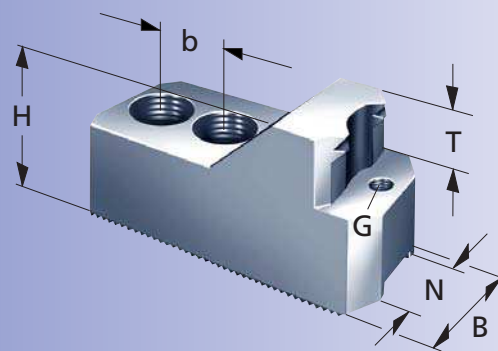

Type	Id.-No.	external clamping	internal clamping	B	H	T	G	N	serration	b	kg/ set	SMW-AUTOBLOK	SMW	Autoblok			
GG-D 004	081050	47-68	110-128	35	40	20	M6	12	1/16" x 90°	16	1,2	AN/AL-D 125 BH/HB/PB-D 130 BB-D 140 SP/STP 125	KDV 130	GHDN 125 ODN 125			
GG-D 005	081051	67-88	92-111							1,2							
GG-D 006	090803	87-102	74-93							1,3							
GG-D 001	081047	25-40	-	35	40	20	M6	12	1/16" x 90°	16	1,2						
GG-D 002	081048	40-60	-							1,2							
GG-D 003	081049	60-80	-							1,1							
GG-D 004	081050	80-100	-							1,2							
GG-D 005	081051	100-120	127-146							1,2							
GG-D 006	090803	120-140	109-127							1,3							
GG-D 010	090732	25-50	-	35	45	20	M6	14	1/16" x 90°	16,5	1,2	HFKN-D 165 SP/STP 160 AN/AL/BH/HB-D 165 BHD-FC 165 PB/PBI/RC-D 165 AP/NT-D 170 BB-D 175 HYND-S 180	SP 160	GHD-FC 165 GHDN 165			
GG-D 011	090733	49-80	145-185							1,2							
GG-D 012	090734	80-120	115-145							1,1							
GG-D 013	090735	119-150	80-115							1,3							
GG-D 014	090736	-	50-80	40	15					1,2							
GG-D 020	081052	40-60	-	35	50	25	M6	17	1/16" x 90°	22	1,2	KDV 160 KDVG 160 KPV 160 KFMF 160 HFK 160					
GG-D 021	081053	60-80	168-188							1,2							
GG-D 022	081054	80-100	144-164							1,1							
GG-D 023	081055	100-120	125-145							1,2							
GG-D 024	081056	120-140	105-125			20				1,3							
GG-D 030	081057	30-60	-	35	50	25	M6	17	1/16" x 90°	22	1,2	HFKN-D 210 SP/STP 200/240 AN/AL/BH/BB-D 210 BHD-FC 210 CC 240Z HB/PB/PBI/RC-D 210 AP/APL/NT-D 215 HYND-S 210/226	KDV 200 KDVG 200 KPV 200 KFMF 200 HFK 200 HFKS 200	CD 200 GHD-FC 210 HDL 200 HDN 200 GHDN 210 ODL/ODN 200 RCD 210			
GG-D 031	081058	60-90	210-240	40	45	20				1,2							
GG-D 032	081059	90-120	180-210	40	45	20				1,2							
GG-D 033	081060	120-150	150-180	40	45	20				1,3							
GG-D 034	090811	-	120-150	40	50	25				1,2							
GG-D 035	090812	-	90-120	40	50	25				1,3							
GG-D 030	081057	40-80	-	35	50	25	M6	17	1/16" x 90°	22	1,2				AP/APL/NT-D 260*	KDV 250 KDVG 250	HDN 220 ODN 220 HDB 220
GG-D 031	081058	80-120	210-290	40	45	20				1,2							
GG-D 032	081059	120-160	175-250	40	45	20				1,2							
GG-D 033	081060	160-200	140-210	40	45	20				1,3							
GG-D 034	090811	-	120-160	40	50	25				1,2							
GG-D 035	090812	-	90-130	40	50	25				1,3							
GG-D 050	081065	40-80	-	45	59	28	M8	21	1/16" x 90°	29	2,5	HFKN-D 260 SP/STP 280 AN/AL/BH/BB-D 250 BHD-FC 250 RC-D 250 HB/PB/PBI-D 250 HYND-S 250	KDV 250 KFMF 250 HFK 250 HFKS 250 HFKS 270 SP/STP/STWP 250 LP 250	RCD 250 GHD-FC 250 HDL/HDN 250 GHDN 250 ODL/ODN 250			
GG-D 051	081066	80-120	250-300	45						2,5							
GG-D 052	081067	120-160	220-260	60						2,6							
GG-D 053	081068	160-210	180-225	60						3,3							
GG-D 054	090817	200-250	140-180	60						3,6							
GG-D 055	090818	-	100-150	60						3,4							
GG-D 056	090819	-	80-120	45	46	15				3,4							
GG-D 060	081069	50-110	-	45	59	28	M8	21	1/16" x 90°	29	3,6				HFKN-D 315 HB/PB/PBI-D 315 SP/SP-L 350 BHD-FC 315 AN/AL/BH/BB-D 315 CC 350Z RC-D 305/400 HYND-S 315 AP/APL/NT-D 315	KDV 315 KDVG 315 KPV 315 KFMF 315 HFK 315 SP/STP/STWP 315	
GG-D 061	081070	100-170	280-350	60						3,5							
GG-D 062	080552	150-220	240-290	60						3,5							
GG-D 063	081071	210-290	175-250	60						3,6							
GG-D 064	090820	280-350	120-180	60	51	20				3,5							
GG-D 080 ¹⁾	081076	100-160	-	60	80	40	M8	25,5	3/32" x 90°	35	9,6	HFKN-D 400/500 AP/AP-L/NT-D 400* BB-N 400/460/500/600 BB-N ES 400/460/500/600 BB-AZ-ES 500 AN/AL/BB-D 400 BH-D 400/450/500/630/800 BHD-FC 400/500/630 IN/L-D 500/630/800 HYD-S 400/500 HYDL-S 400/500/550/630/800 HYDLL-S 550/630	KDV 500 KDVG 500 KPV 400/500 KPV 630/800 HFKS 400 HFK 400 HFK 500 HFKS 500				
GG-D 081 ¹⁾	019355	160-240	-							7,7							
GG-D 082 ¹⁾	081077	240-320	270-380							7,1							
GG-D 083 ¹⁾	081078	320-400	190-290							8,4							
GG-D 084 ¹⁾	081079	350-460	140-230							9,1							
GG-D 085 ¹⁾	081080	-	100-160	60	20					9,0							

¹⁾ clamping range valid for chuck Ø 400

* with single T-nuts only

