

hard roughing jaws for bar work

GSG-D

INCH serration
1/16" x 90° or 3/32" x 90°

serration ground

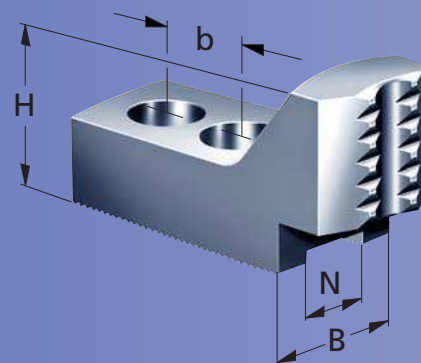

Type	Id.-No.	clamping ranges Ø	B	H	N	serration	b for DIN 912	kg/set	SMW-AUTOBLOK	SMW	Autoblok
GSG-D 165 ¹⁾	091343	15-40	30	40	14	1/16" x 90°	22 M10	1,2	HFKN-D 165 SP/STP 160 AN/AL/BH/HB-D 165* BHD-FC 165* PB/PBI/RC-D 165* AP/NT-D 170* BB-D 175* HYND-S 180*	SP 160 STP 160	GHD-FC 165 GHDN 165
GSG-D 200 ²⁾	091344	15-50	40	40	17	1/16" x 90°	22 M12	1,5	HFKN-D 210 SP/STP 200/240 AN/AL/BH/BB-D 210 BHD-FC 210 CC 240Z HB/PB/PBI/RC-D 210 AP/APL/NT-D 215 AP/APL/NT-D 260* HYND-S 210/226	KDV 200/250 KDVG 200/250 KFV 200 HFK/HFKS 200 KFMF 200	ODL 200 ODN 200/220 HDL 200 HDN 200/220 GHD/FC 210 GHDN 210 HDB 220 CD 200 210 RCD
GSG-D 250 ³⁾	091345	20-70	50	50	21	1/16" x 90°	28 M16	3,5	HFKN-D 260/315 SP/STP 280 SP/SP-L 350 AN/AL/BH/BB-D 250* AN/AL/BH/BB-D 315* BHD-FC 250/315* RC-D 250/305/400* CC 350Z HB/PB/PBI-D 250/315* AP/APL/NT-D 315* HYND-S 250/315*	KDV 315/400 KDVG 315/400 KFV 250/315 HFK/HFKS 250/270/315 KFMF 250/315	ODL 250/315/400 ODN 250/315/400 HDL 250/315/400 HDN 200/315/400 GHD/FC 250/305/400 GHDN 250/315/400 HDB 300 CD 250/315-65/315-85 250 RCD 305 RCD
GSG-D 400 ⁴⁾	091346	40-100	60	60	25,5	3/32" x 90°	35 M20	8,0	HFKN-D 400/500 AP/AP-LNT-D 400* BB-N 400/460/500/600 BB-N ES 400/460/500/600 BB-AZ-ES 500 AN/AL/BB-D 400 BH-D 400/450/500/630/800 BHD-FC 400/500/630 IN/L-D 500/630/800 HYD-S 400/500 HYDL-S 400/500/550/630/800 HYDLL-S 550/630	KDV 500 KDVG 500 KFV 400/500/630/800 HFK/HFKS 400/500	
GFB-D 1	016348	5-25	25	39	10	1/16" x 90°	M8		GF 80		
GFB-D 2	016349	25-45	30								
GFB-D 3	016350	45-65									
GFB-D 4	016351	65-80									
GFB-D 5	016352	80-100									

* with single T-nuts only

1) clamping range valid for chuck Ø 165

2) clamping range valid for chuck Ø 210

3) clamping range valid for chuck Ø 260

4) clamping range valid for chuck Ø 400

