

hard roughing jaws

SGA-M for external clamping

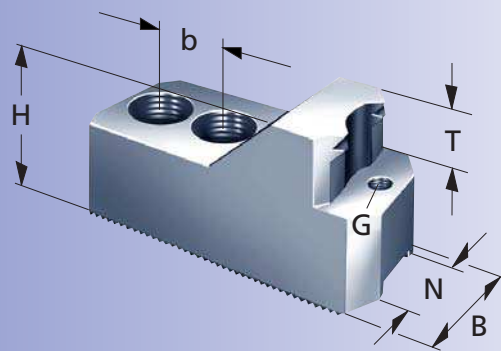

METRIC serration
1,5 x 60°

serration ground

Type	Id.-No.	clamping range Ø	B	H	T	G	N	serration	b	kg/ set	SMW-AUTOBLOK	Howa	Kitagawa	Schunk
SGA-M 010	081156	30-45	30	40	20	M6	12	1,5 x 60°	20	1,0	HFKN-M 165	HO7MA6	AS 165	HSL 165
SGA-M 020	081157	40-65									AN/AL/BH/-M 165	HO15M6	B-06/-106/-160/-206	ROTA NC plus 185
SGA-M 030	081158	65-85									BHM-FC 165	HO22M6	BB-06/-206 • BL-206	ROTA NCF plus 185
SGA-M 040	081159	85-105									RC-M 165	HO24M6	B-07 • HJA 5-6	ROTA NCD 165-185
SGA-M 050	081160	105-125			15						AP/NT-M 170	HO27M6	HOB-6 • HO-6	ROTA NCK
											BB-M 175	HO37M6	HOH-06/-106/-160/-206	ROTA NCK plus 165
											HB/PB/PBI-M 165	HO47M6	HOS 6	ROTA NC/NCF 165
													N-06/-160 • NL-06	
SGA-M 060	081161	30-50	35	50	25	M6	14	1,5 x 60°	25	1,4	HFKN-M 210	HO7MA8	AS 210	HSL 210
SGA-M 070	081162	50-75									AN/AL/BH/BB-M 210	HO15MA8	B-08/-108/-200/-208	ROTA NCD/NCK 210
SGA-M 080	081163	75-100									BHM-FC 210	HO23MA8	BB-08/-208 • BL-208	ROTA NC 210
SGA-M 090	081164	100-130		40	15						RC-M 210		HJA 6-8 • HO 8 • HOB 8	ROTA NCF 210
SGA-M 100	081165	130-160	40	40	15						AP/APL/NT-M 215		HOH-8/-108/-200/-208	ROTA NCK plus 210
											HB/PB/PBI-M 210		HOS 8	ROTA NC plus 215
													N-08/-200 • NL-08	NCF plus 215
SGA-M 200	081175	40-65	40	50	25	M6	16	1,5 x 60°	30	1,4	HFKN-M 260		AS 250	HSL 250
SGA-M 210	081176	65-100									AN/AL/BH/BB-M 250		B-10/-110/-210/-210X/-250	ROTA NC/NCD 250
SGA-M 220	081177	100-150									BHM-FC 250		BB-10/-210 • BL-210	ROTA NCF/NCK 250
SGA-M 230	081178	150-200	35								RC-M 250		HJA 6-10/8-10	ROTA NCK plus 250
											AP/APL/NT-M 260		HO-10 • HOB-10	ROTA NC plus 260
											HB/PB/PBI-M 250		HOH-10/-110/-210/-250	ROTA NCF plus 260
													HOS-10	
													N-10/-250 • NL-10	
SGA-M 331	081186	50-100	50	60	25	M8	21	1,5 x 60°	30	4,2	HFKN-M 315		B 212	HSL 315
SGA-M 341	081187	100-160									BHM-FC 315		BB-212	ROTA NCD/NCK 315
SGA-M 351	081188	160-230									AN/AL/BH/BB-M 315		BL-212	ROTA NC/NCK plus 315
SGA-M 361	081189	230-300									RC-M 305			ROTA NCF plus 315
											AP/APL/NT-M 315			
											HB/PB/PBI-M 315			
SGA-M 331	081186	128-186	50	60	25	M8	21	1,5 x 60°	30	4,2	GH-M 400			
SGA-M 341	081187	178-246									RC-M 400			
SGA-M 351	081188	238-316												
SGA-M 361	081189	308-386												
SGA-M 371	085743	60-100	60	80	34	M8	22	1,5 x 60°	43	4,2			B-15/-18	HSL 400
SGA-M 372	085744	100-150											B-380/-450	ROTA NC/NCF 400
SGA-M 373	085745	150-200											HOH-15	
SGA-M 374	085746	200-250											HOH-15K	
SGA-M 375	085747	250-300								4,3			HOH-380	
SGA-M 376	085748	300-350								4,3				

hard top jaws
METRIC serration

stop pins

ALB

Type	Id.-No.	G	H	SW
ALB 605	016513	M6	5	10
ALB 610	016511		10	
ALB 615	016512		15	
ALB 620	017602		20	
ALB 805	017603	M8	5	13
ALB 810	016514		10	
ALB 815	016515		15	
ALB 820	016516		20	
ALB 825	081191		25	

