

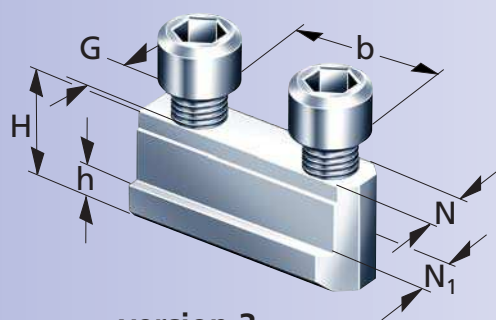

version 2



version 3

Howa	Kitagawa	Schunk
	B204 • B205	
HO 1 MA 6 • HO 7 MA 6 • HO 24 M 6 • HO 27 M 6 HO 15 M 6 • HO 22 M 6 • HO 47 M 6 • HO 37 M 6	HJA 5-6 • HO 6 • N-160 • HOS 6 • HOH 06 • N 160 B 06 • N 06 • B-160 • HOB 6 • AS 165 • HOH-160 B-206 • B 06 • B 106 • B 07 • HOH 106 • HOH 06 BB 06 • BB 206 • HOH 206	HSL 165 (1,5 x 60°) ROTA NC/NCF 165 ROTA NCK 165 • ROTA NCK Plus 165
HO 1 MA 8 • HO 2 MA 8 • HO 23 M 8 • HO 7 M 8 HO 15 M 8	HJA 6-8 • HO 8 • HOH 08 • N-200 • HOS 8 • B 08 B-200 • HOB 8 • AS 210 • HOH-200 • N 08 • N 200 B-208 • B 108 • HOH 108 • HOH 208 B 208 • BB 208 • BB 08	HSL 210 (1,5 x 60°) ROTA NC/NCF 210
HO 1 MA 10 • HO 2 M 10	B-250 • AS 250 • HOS 10 • B 10 • AS 250 HOB-10 • HO-10 • HJA 8-10 • HOH 250 • N 10 • N 250	HSL 250 (1,5 x 60°) ROTA NC/NCF 250
HO 7 MA 10 • HO 15 M 10 • HO 22 M 8 HO 47 M 8 • HO 23 M 10 • HO 27 M 8 HO 24 M 8 • HO 37 M 8	B-110 • HOH 110 • B-210 • HOH 210 • BB 210 • BB 10	ROTA NCK 250 • ROTA NCK Plus 250
HO 1 MA 12 • HO 2 M 12	B-300 • HO-12 • HOH-300 • HOS 12 • B 12 • N 12 HOH 12 • N-300 • HOB 12 • HLA 6-12 • HLA 6-15 HLA 8-12 • HJA 8-15	ROTA NC/NCF 315
HO 7 MA 12 • HO 22 M 10 • HO 23 M 12 HO 37 M 10 • HO 27 M 10 • HO 24 M 10 HO 15 M 12 • HO 47 M 10		HSL 315
	B 212 • HOH 212 • B-112 • HOH 112	ROTA NCK 315 • ROTA NCK Plus 315 • ROTA NCD 315 ROTA NC/NCF Plus 315
	BB 212 B-380 • B-15 • B-18 • B-450 • HOH 380 HOH-18 • HOB-15 • HOB 18 • HOH 15	HSL 400 ROTA NC/NCF 400

T-nuts  
grippers

 Please observe!  
Always tighten T-nuts  
with a torque wrench.