

# Прецизионные механизированные патроны

Ø 170 - 400 мм

■ закрытый центр

■ 3 кулачка

■ proofline патрон = герметичен - редкий ремонт

# AP-C

газовое соединение

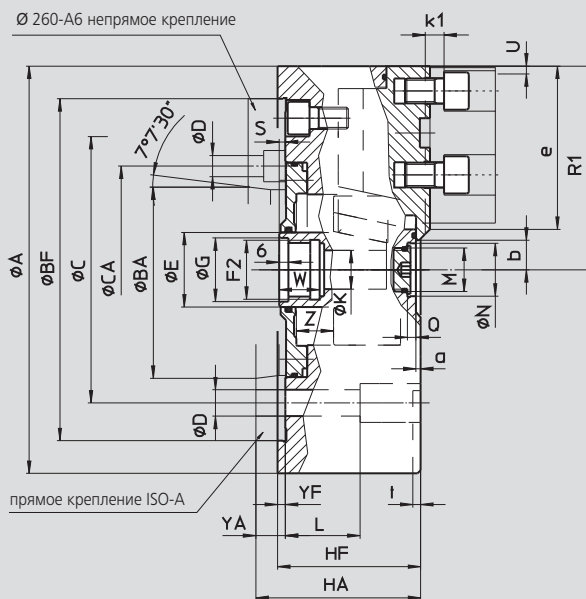
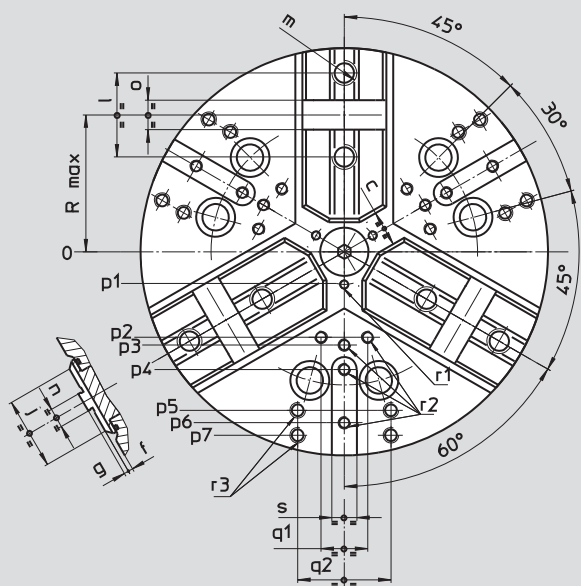

ВОЗМОЖНЫ ИЗМЕНЕНИЯ

SMW-AUTOBLOK тип			AP-C 170		AP-C 215		AP-C 260			AP-C 315		AP-C 400	
тип крепления			Z140	A5	Z170	A6	Z220	A6	A8	Z220	A8	Z300	A11
	A	mm	172		216		262			315		390	
	Bf/BA	H6 mm	140	82.563	170	106.375	220	106.375	139.719	220	139.719	300	196.869
	C	mm	104.8		133.4		171.4			171.4		235	
	Ca	mm					133.4						
	D	mm	11.5		13.5		17			17		21	
	E	mm	32		42		48			48		75	
	F2	mm	M24 x 2		M32 x 1.5		M38 x 1.5			M38 x 1.5		M60 x 1.5	
	G	H8 mm	25		33		39			39		61	
	Hf/HA	mm	68	78	81	93	92	111	106	101	115	112	127
	K	mm	18.5		20		25			25		48	
	L	mm	23		32		38			38		54	
	M	mm	M22 x 1.5		M22 x 1.5		M28 x 1.5			M28 x 1.5		M52 x 1.5	
	N	H9 mm	24		24		34			34		60	
	Q	mm	5.5		5.5		5.5			5.5		9	
патрон открыт	R1	mm	86.5		108		131			157.5		195	
max.	R	mm	56		72		88			105		133.5	
max./min.	S	mm	21/4		26/4		28/4			34/4		37/4	
рад. ход кулачка	U	mm	3.6		4.6		5			6.3		7	
	W	mm	22		26		26			26		38	
	Yf/YA	mm	5	15	5	17	5	24	19	5	19	6	21
max./min.	Z	mm	17/0		22/0		24/0			30/0		33/0	
	a	mm	3		3		3			3		3	
min.	b	mm	8.5		12		14			16.5		31	
min.	c	mm	9		13		14			16		38	
	e	mm	70		87		107			129		150	
	f	mm	3		3		3			3		6	
	g	mm	3		3		3			3		3	
	j	mm	34		46		48			58		63	
	k1	mm	10		11		12			12		14	
	l	mm	38		44.4		54			63.5		76.2	
	m	mm	M10		M12		M16			M16		M20	
	n	h8 mm	7.94		7.94		12.70			12.70		12.70	
	o	H7 mm	12.68		12.68		19.03			19.03		19.03	
	p1	mm	16		16		21			21		37.5	
	p2	mm	-		-		-			60		80	
	p3	mm	38		49		55			62.5		83	
	p4	mm	-		80		70			80		110	
	p5	mm	65		80		102			102		140	
	p6	mm	70		-		102			120		155	
	p7	mm	-		-		-			135		170	
	q1	mm	-		-		-			30		36	
	q2	mm	36		45		60			60		80	
	r1	mm	M5/7		M5/8		M6/10			M6/10		M6/12	
	r2	mm	M6/14		M8/17		M8/17			M8/17		M10/19	
	r3	mm	M8/17		M8/17		M10/19			M10/19		M12/22	
	s	mm	16		16		16			16		20	
	t	mm	5		5		5			5		5	