

Прецизионные механизированные патроны

Ø 80 - 315 мм

- ДЛИННЫЙ ХОД
- закрытый центр
- 2 кулачка

CL-C

пазовое
соединение

CL-D

ДУЙМОВОЕ
зубчатое соединение

1

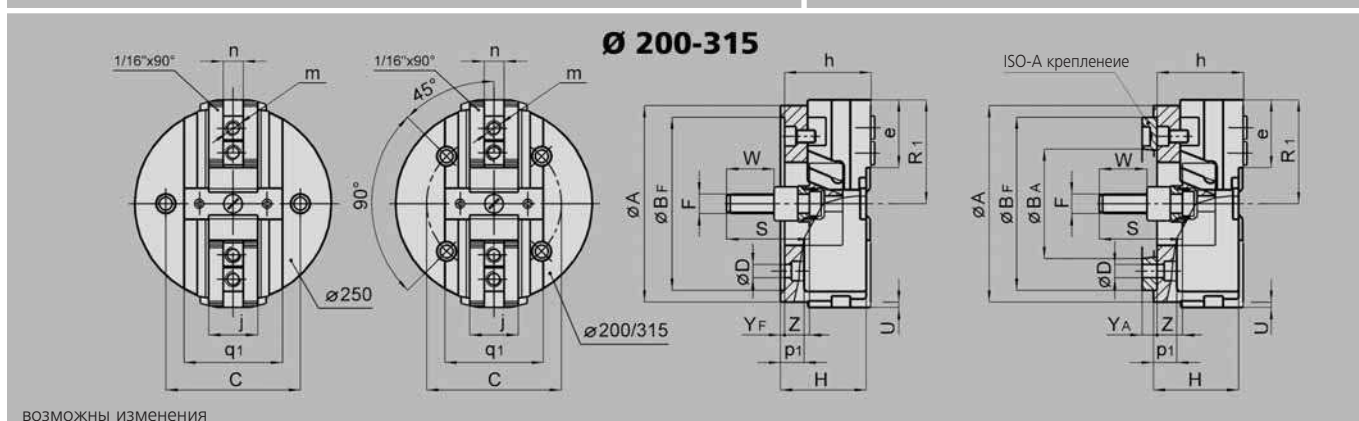
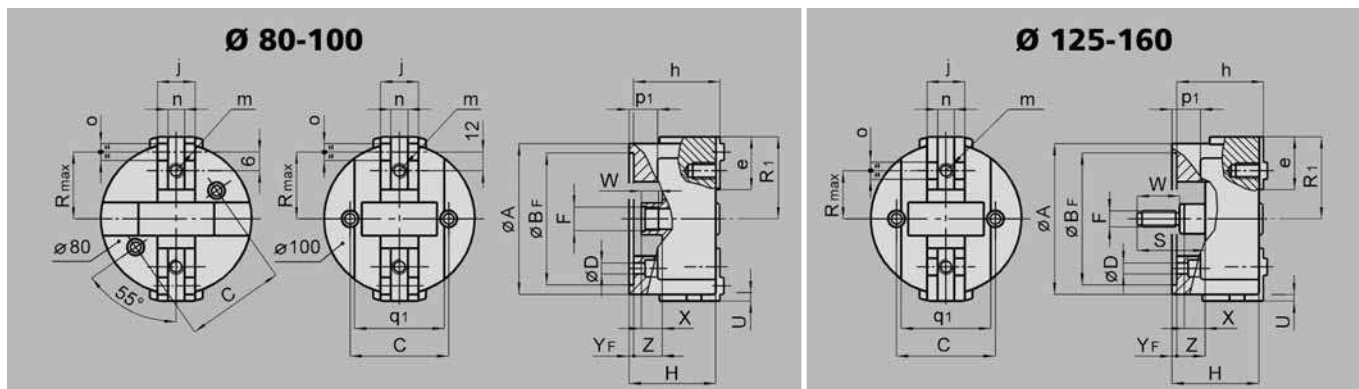

возможны изменения

SMW-AUTOBLOK тип		CL-C 80 пазовое		CL-C 100 пазовое		CL-C 125 пазовое		CL-C 160 пазовое		CL-D 200 дюймовое		CL-D 250 дюймовое		CL-D 315 дюймовое	
тип крепления		Z74	-	Z92	-	Z115	-	Z140	A5	Z170	A6	Z220	A8	Z220	A8
	A	mm	80	100	125	160	200	250	315						
	B _F H6	mm	74	92	115	140	170	220	220						
	B _A	mm	-	-	-	-	82.563	106.375	139.719						
	C	mm	60	75	92	104.8	133.4	171.4	171.4						
	D	mm	9	11	13.5	12	13.5	17	17						
	F	mm	M16 x 1.5	M18 x 1.5	M16	M16	M20	M24	M24						
	H _F H _A	mm	45	54	76	92	102	103	115	109	123	114	128		
патрон открыт	R ₁	mm	40	50	68	87	108	132	165						
	R _{max}	mm	32.4	43	38	51	-	-	-						
	S	mm	-	-	49	109	97	105	105						
ход кулачка	U	mm	4.4	5.5	8	10	12	13	14						
	W	mm	12	16	40	52	55	60	60						
	X	mm	14	11	6	22	8	10	10						
	Y _F Y _A	mm	4	4	4	5	15	5	19	5	19	5	19		
max./min.	Z	mm	11/0	14/0	26/6	30/5	30/0	32/0	37/2						
	e	mm	24.5	32	46	56	70	86	120						
	h	mm	45	54	76	91	104	110	115						
	j	mm	20	22	30	40	50	62	62						
	m	mm	M8	M10	M12	M16	M16	M20	M20						
	n h8	mm	8	8	14	18	21	25.5	25.5						
	o	mm	8	8	16	18	-	-	-						
	p ₁	mm	-	22	30	30	31	33	36						
	q ₁	mm	-	60	75	95	110	125	140						