

Прецизионные механизированные патроны

Ø 500 - 800 мм

- БОЛЬШОЕ ПРОХОДНОЕ ОТВЕРСТИЕ
- 3 кулачка

ВН-D большие диаметры

ДЮЙМОВОЕ
зубчатое соединение

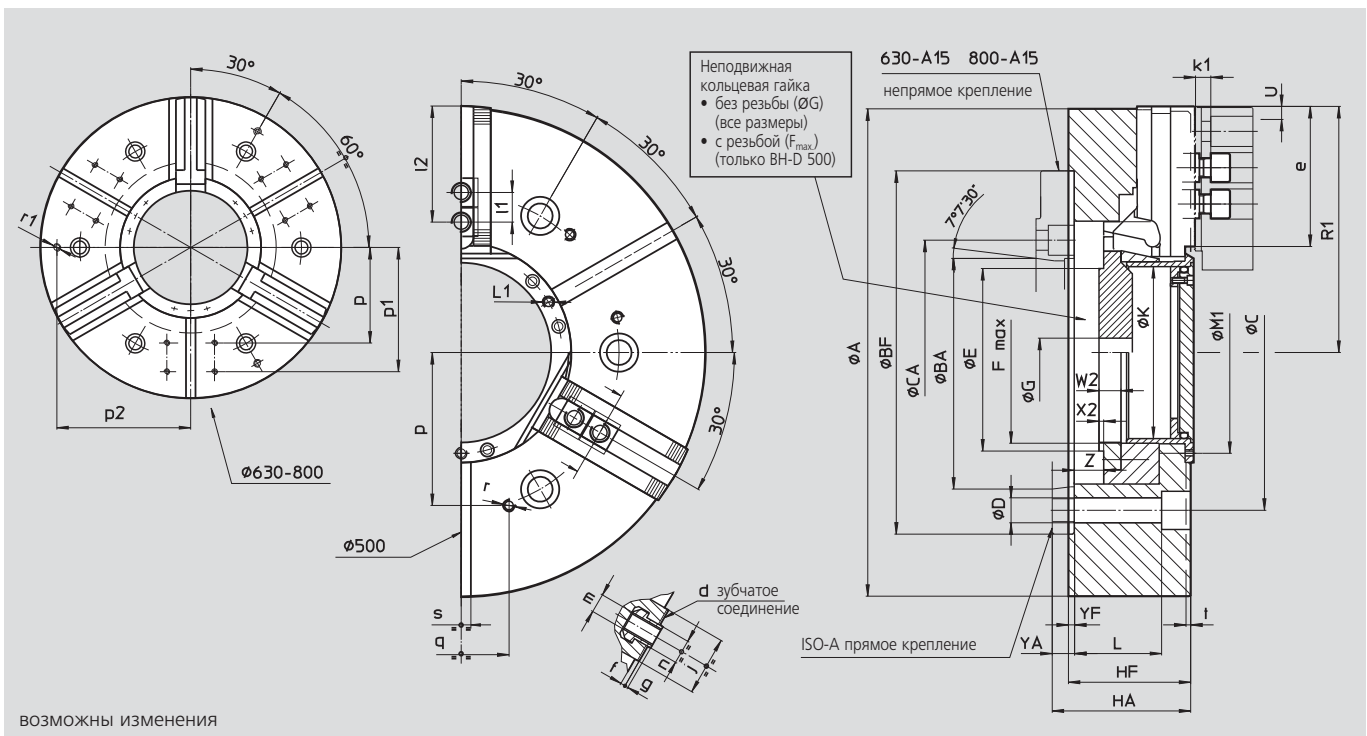

SMW-AUTOBLOK тип			ВН-D 500		ВН-D 630			ВН-D 800		
тип крепления			FL380	A15	FL520	A15	A20	FL520	A15	A20
A	mm		510		630			800		
B _f /B _A	H6 mm		380	285.775	520	285.775	412.775	520	285.775	412.775
C	mm		330.2		463.6	-	463.6	463.6	-	463.6
CA	mm		-	-	-	330.2	-	-	330.2	-
D	mm		26		26			26		
E	mm		206		260			260		
F _{max}	mm		M190 x 3		M250 x 3 (*)			M250 x 3 (*)		
G	mm		30		30			30		
H _f /H _A	mm		128	145	150	184	169	150	184	169
K	mm		180		230			230		
L	mm		91		99			99		
L ₁	mm		M8/9		M8/16			M8/16		
M ₁	mm		211		270			270		
патрон открыт	R ₁	mm	257.5		314			399		
ход кулачка	U	mm	6.5		9			9		
	W ₂	mm	23		23			23		
	X ₂	mm	5		5			5		
	Y _f /Y _A	mm	6	23	6	40	25	6	40	25
max./min.	Z	mm	31/0		34/0			34/0		
ВН-D зубчат. соед.	d	дюйм	3/32" x 90°		3/32" x 90°			3/32" x 90°		
	e	mm	146.5		152			237		
	f	mm	5		10			10		
	g	mm	3.5		3.5			3.5		
	j	mm	62		62			62		
	k ₁	mm	16		16			16		
	l ₁	mm	38		38			38		
max./min.	l ₂	mm	121/53		127/53			212/53		
	m	mm	M20		M20			M20		
	n	h8 mm	25.5		25.5			25.5		
	p	mm	160		200			200		
	p ₁	mm	-		260			260		
	p ₂	mm	-		280			280		
	q	mm	100		100			100		
	r	mm	M12/22		M12/22			M12/22		
	r ₁	mm	-		M16/28			M16/28		
	s	H12 mm	20		20			20		
	t	mm	5		5			5		

(*) патроны ВН-D 630 и 800 поставляются с кольцевой гайкой (Ø G) без резьбы