

Quick jaw change ma

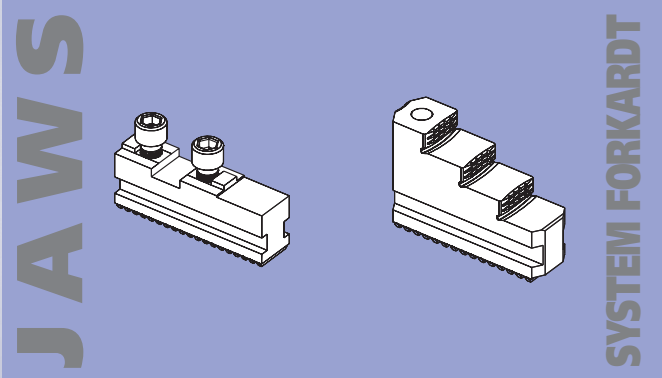

HG-F

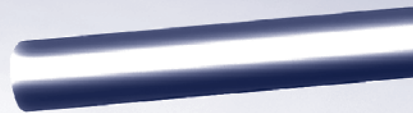

■ Jaw change in less than 1 minute

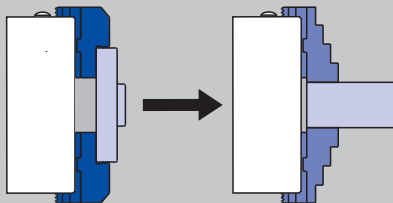

■ Universal, because jaws can be radially adjusted and reversed = less jaw sets

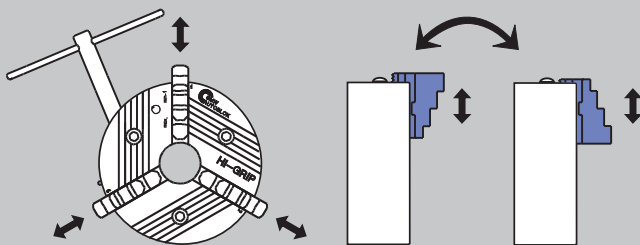

Jaws radially adjustable

Jaws 180° reversed

For highest speeds
Flat gripping force curve

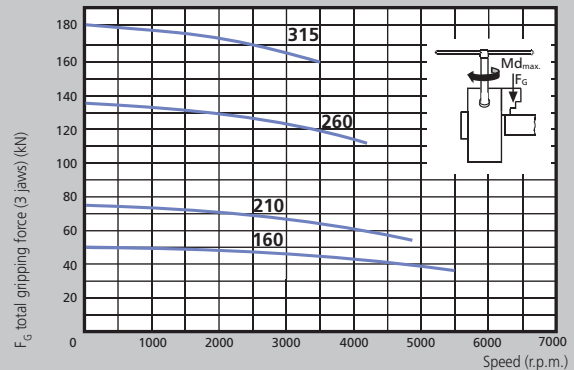

■ The max. gripping force is the total, acting on the 3 jaws, obtained by applying to the chuck the max. allowed driving torque. The data refers to a chuck newly maintained according to their service manual, using SMW K05 grease.

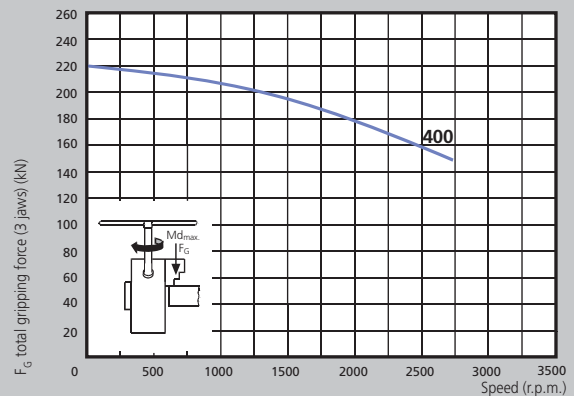

■ The dynamic gripping forces have been measured using hardened standard stepped monoblock jaws type GST placed in a position not exceeding the outer diameter of the chuck.

▲ **Safety advice/danger of damage:**

When using taller/havier jaws and/or clamping on a more external position reduce driving torque/rotating speed accordingly.