

SF-RAZ

Main dimensions and technical data

Data sheet shows no jaw dimensions and radial covers for switches and adjustments
Data sheet shows only general dimensions!

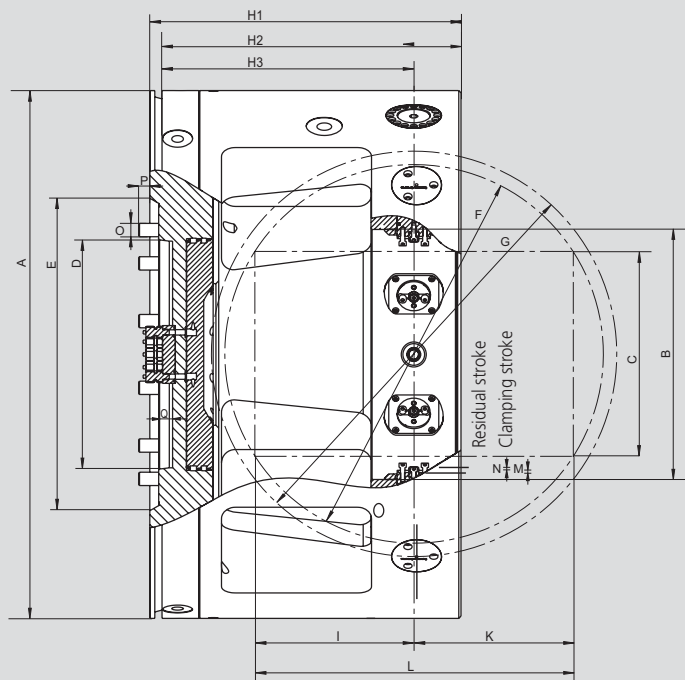
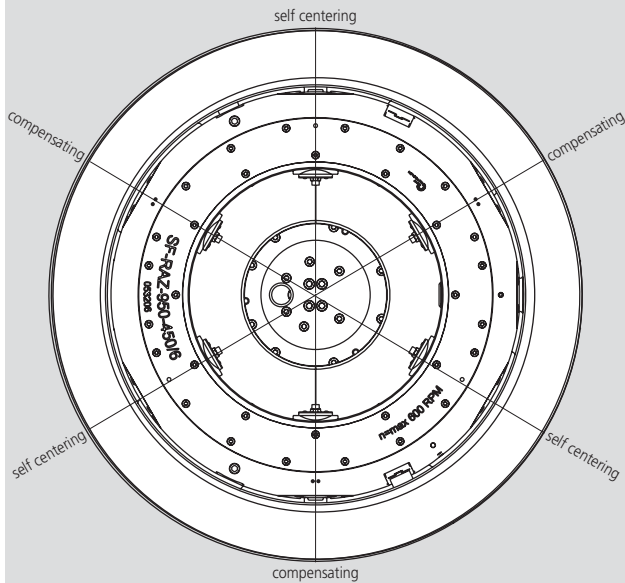

Subject to technical changes
For more detailed information please ask for customer drawing

SMW-AUTOBLOK Type			SF-RAZ 750	SF-RAZ 840	SF-RAZ 950	SF-RAZ 1050
Id. No.			053090	053097	053206	053900
Chuck o.d.	A	mm	750	840	950	1050
Indexing ring i.d.	B	mm	250	340	450	550
Max. workpiece o.d.	C	mm	185	275	368	468
Spindle mounting	D		A15	A15	A20	A20
Recess for spindle o.d.	E	mm	435	435	562	562
Max. swing workpiece	F	mm	480	570	680	780
Swing indexing ring	G	mm	526	618	728	828
	H1	mm	456	501	560	610
	H2	mm	440	485	544	594
	H3	mm	355	400	459	509
	I	mm	221.5	250	286	312
	K	mm	221.5	250	286	312
Max. length of workpiece	L	mm	443	500	572	624
Clamping at rec. clamping stroke	M	mm	5.5	5.5	5.5	5.5
Recom. residual stroke	N	mm	4.5	4.5	4.5	4.5
Total jaw stroke	S	mm	10	10	10	10
Mounting bolts	O	mm	M24	M24	M24	M24
	P	mm	37	37	36	36
Max. speed		r.p.m.	800	700	600	530
Max. pressure		bar	70	70	70	70
Max. grip force		kN	250	250	250	250
Mass		kg	1018	1290	1650	2155

Installation of SF-RAZ with hydraulic manifold, electric manifold and hose kit: (All these accessories must be ordered separately)

