

High precision power chucks \varnothing 165 - 400 mm

AN-C

- closed center
- 2 and 3 jaws (4 jaws only \varnothing 400 mm)

Tongue & groove

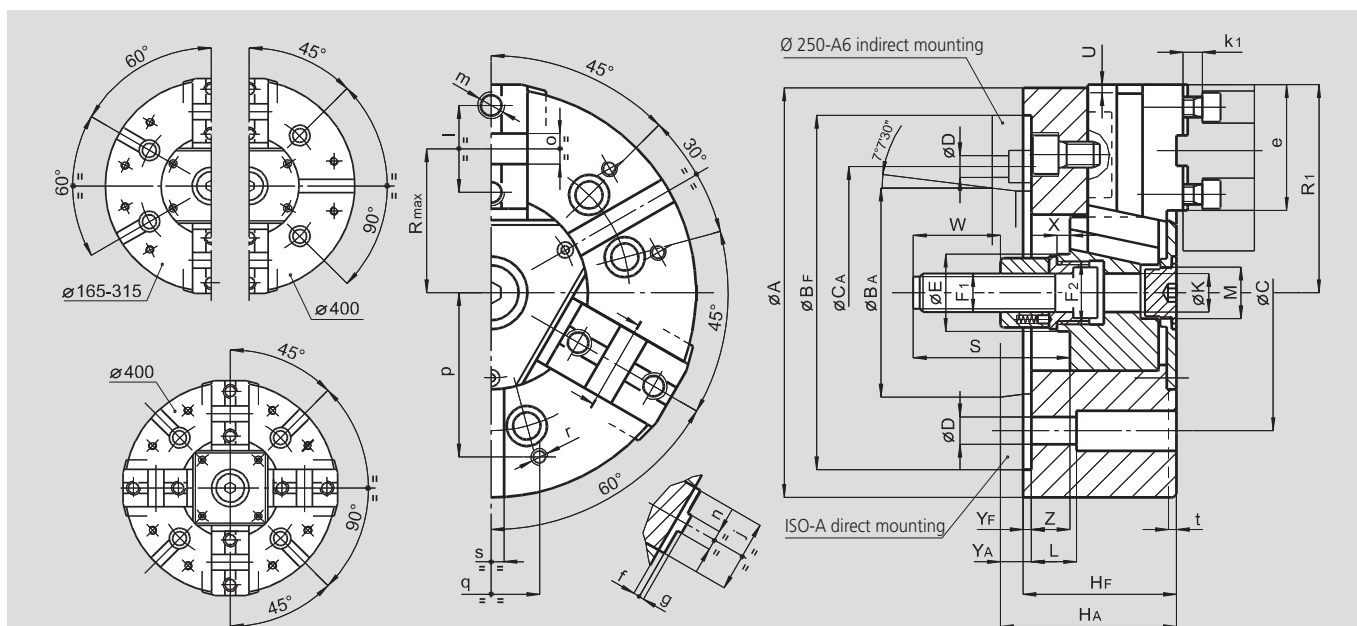

Subject to technical changes
For more detailed information please ask for customer drawing

SMW-AUTOBLOK Type			AN-C 165		AN-C 210		AN-C 250			AN-C 315		AN-C 400	
Mounting			Z140	A5	Z170	A6	Z220	A6	A8	Z220	A8	Z300	A11
	A	mm	165		210		254			315		390	
	Bf/BA H6	mm	140	82.563	170	106.375	220	106.375	139.719	220	139.719	300	196.869
	C	mm	104.8		133.4		171.4	-	171.4	171.4		235	
	CA	mm	-	-	-	-	-	133.4	-	-	-	-	-
	D	mm	11.5		13.5		17	13.5	17	17		21	
	E	mm	32		41		47			47		86	
	F1	mm	M16		M20		M24			M24		M24	
	F2	mm	M24 x 2		M32 x 1.5		M38 x 1.5			M38 x 1.5		M75 x 2	
	Hf/HA	mm	71	81	85	97	95	114	109	105	119	116	131
	K	mm	17		20		25			25		65	
	L	mm	23		32		28			38		54	
Chuck open	R1	mm	83		105		128			158		196	
max.	R	mm	56		72		88			105		133.5	
Jaw stroke	S	mm	104		97		103			103		105	
	U	mm	3.6		4.4		5			6.3		7	
	W	mm	52		55		60			60		60	
	X	mm	17		8		8			8		8	
	Yf/YA	mm	5	15	5	17	5	24	19	5	19	6	21
max./min.	Z	mm	17/0		21/0		24/0			30/0		33/0	
	e	mm	54		71		77			99		116	
	f	mm	4		4		4			4		7	
	g	mm	3		3		3			3		3	
	j	mm	30		36		45			45		62	
	k1	mm	10		11		12			12		14	
	l	mm	38		44.4		54			63.5		76.2	
	m	mm	M10		M12		M16			M16		M20	
	n h8	mm	7.94		7.94		12.70			12.70		12.70	
	o H7	mm	12.68		12.68		19.03			19.03		19.03	
	p	mm	65		80		102			120		150	
	q	mm	36		45		60			60		80	
	r	mm	M8		M8		M10			M10		M12	
	s	mm	16		16		16			16		20	
	t	mm	5		5		5			5		5	