

SLU-X

Self-centering steady rests
Standard line

- Sealed body
- Stroke control for end position open (switch not included)

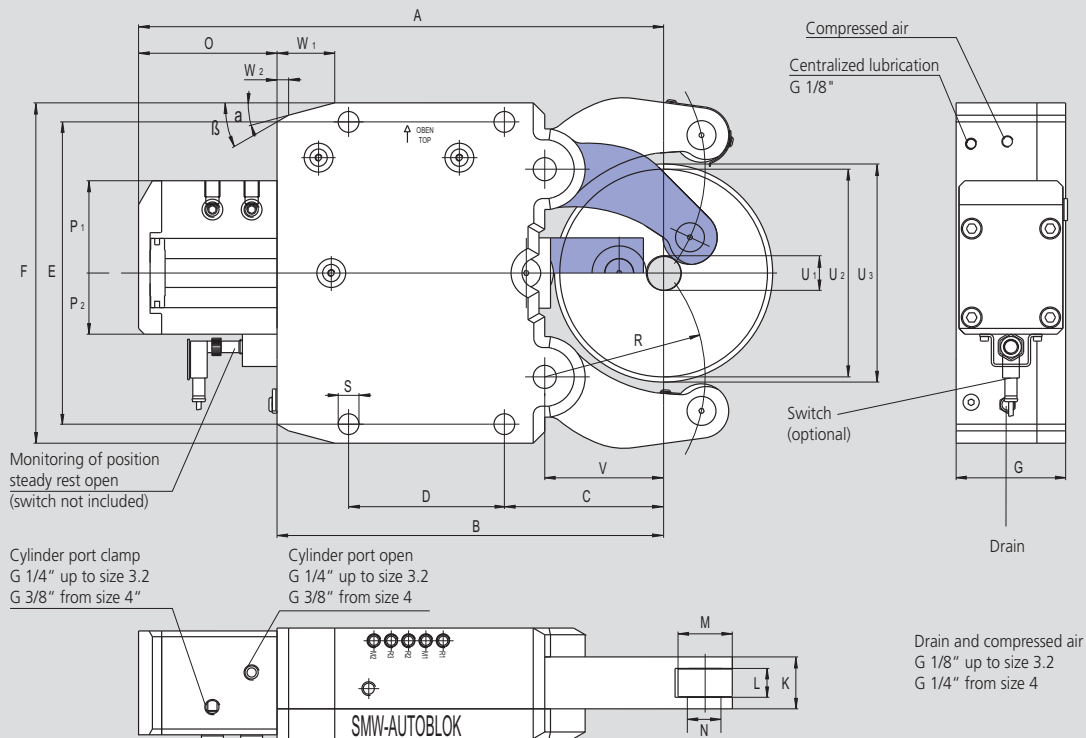

Subject to technical changes
For more detailed information please ask for customer drawing

SMW-AUTOBLOK Type Size		SLU-X 1	SLU-X 2	SLU-X 3	SLU-X 3.1	SLU-X 3.2	SLU-X 4	SLU-X 5	SLU-X 5.1
Centering range without chip guard	U1	6	8	12	20	50	30	45	85
	U2	70	101	152	165	200	245	310	350
	U3	75	106	164	172	202	253	318	352
Max. axial clearing dia.	U3	75	106	164	172	202	253	318	352
Centering range with chip guard 3-piece	U1	11	16	16	20	50	30	45	85
	U2	64	101	152	165	200	245	310	350
	U3	75	106	164	172	202	253	318	352
	A	214.5	277	428	436	455	603	697	717
	B	149	195	312	320	335	448	510	530
	C	52	70	115	123	138	146	178	198
	D	66	85	135	135	135	240	270	270
	E	140	170	262	262	262	365	400	400
	F	160	195	295	295	295	405	440	440
	G	63	75	95	95	95	110	145	145
	K	28	35	45	45	45	60	75	75
Roller width	L	15	19	25	25	25	25	29	29
Roller diameter	M	24	35	47	47	47	52	62	62
	N	8	15	20	20	20	25	30	30
	O	65.5	82	116	116	120	155	187	187
	P1	53	63	85	85	85	91	97	97
	P2	29	40	53	53	53	61	63	63
	R	55	74	119	124	139	172	209	229
	S	11	14	18	18	18	23	23	23
	V	37	51	85	93	103	128	160	180
	W1	20	30	50	50	50	58	62	62
	W2	5	11.2	10	10	10	18.3	19.1	19.1
	α	15°	15°	15°	15°	15°	15°	18°	18°
	β	45°	30°	30°	30°	30°	40°	40°	40°
Piston area*	cm ²	7	19.6	38.5	38.5	38.5	63.6	78.5	78.5
Operation pressure min./max.	bar	6/70	8/70	8/80	8/80	8/80	8/70	8/80	8/80
Max. clamping force/roller	daN	165	450	1000	1000	1000	1500	2000	2000
Centering accuracy within the whole range	mm	0.02	0.02	0.04	0.04	0.04	0.05	0.06	0.06
Repeatability accuracy	mm	0.005	0.005	0.007	0.007	0.007	0.007	0.01	0.01
Max. roller surface speed	m/min	800	800	725	725	725	715	600	600
Mass approx.	kg	8	14	48	57	59	117	174	178

* On request cylinder differing from standard available
Subject to technical changes!