

Extra compact with side mounted cylinder
Additional pivoting upper arm for vertical loading

SLUA-B

Self-centering steady rests
 Standard line

■ Special sizes on request

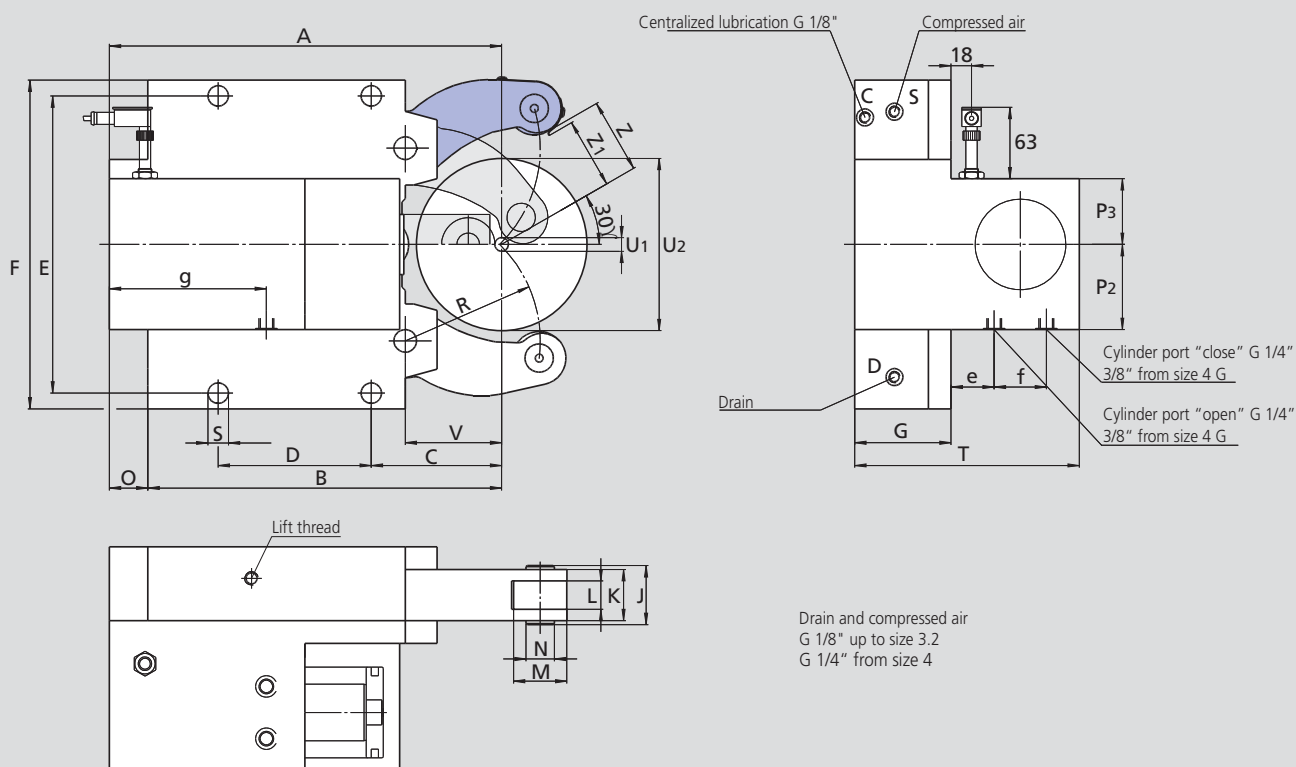

Subject to technical changes
 For more detailed information please ask for customer drawing

SMW-AUTOBLOK Type Size		SLUA-B 3	SLUA-B 3.1	SLUA-B 4	SLUA-B 5	SLUA-B 6
Centering range	U1	12	22	35	50	160
	U2	130	150	220	268	460**
	U1	16	22	35	50	160
	U2	130	150	220	268	460**
	Z	66	76	111	135	230**
	Z1	62	72	106.5	130	225**
	A	346	354	480	600.5	800
	B	312	320	448	510	709
	C	115	123	146	178	215
	D	135	135	240	270	330
	E	262	262	365	400	610/640
	F	290	290	400	440	680
	G	85	85	110	145	145
	J	52	52	67	83	83
Roller width	K	45	45	60	75	75
	L	25	25	25	29	29
	M	47	47	52	62	80
	N	25	25	32	36	42
	O	34	34	32	90.5	91
	P2	75	75	68	85	87
	P3	58	58	85	85	104
	R	119	124	172	209	290
	S	18	18	23	23	27
	T	198	198	243.5	325	350
	V	85	93	128	160	175
	e	38	38	38.5	79.5	74.5
	f	46	46	66	66	96
	g	138.5	138.5	188	210	230
Piston area*	cm ²	19.6	19.6	47.7	47.7	136.8
Operating pressure min/max.	bar	8/60	8/60	8/60	8/80	8/70
Max. clamping force/roller	daN	1000	1000	1500	2000	3000
Centering accuracy within the whole range	mm	0.04	0.04	0.05	0.06	0.06
Repeatability accuracy	mm	0.007	0.007	0.007	0.01	0.01
Max. roller surface speed	m/min	725	725	715	600	560
Mass approx.	kg	45	46	106	175	483

* On request cylinder differing from standard available

** SLUA-B-6: Loading diameter U2 = 460 only under 19° installation