

SF-RAZ – характеристики

Обработка резьбы за одну установку

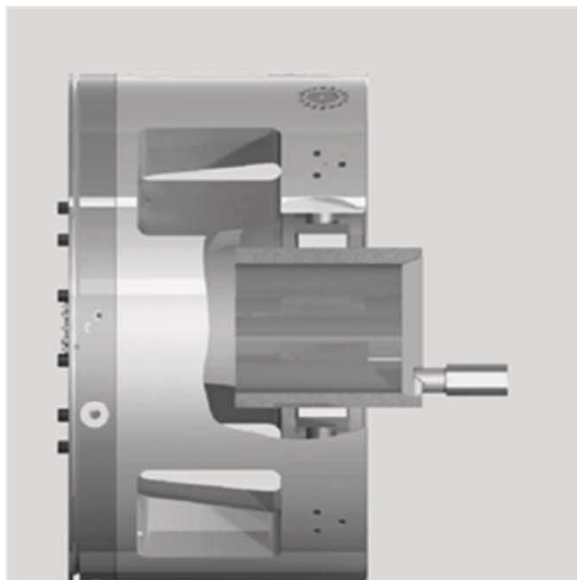

Fig. 1
Clamping the coupling on the outside diameter with 6 jaws (3 self centering and 3 compensating jaws) and machining the thread on side 1.

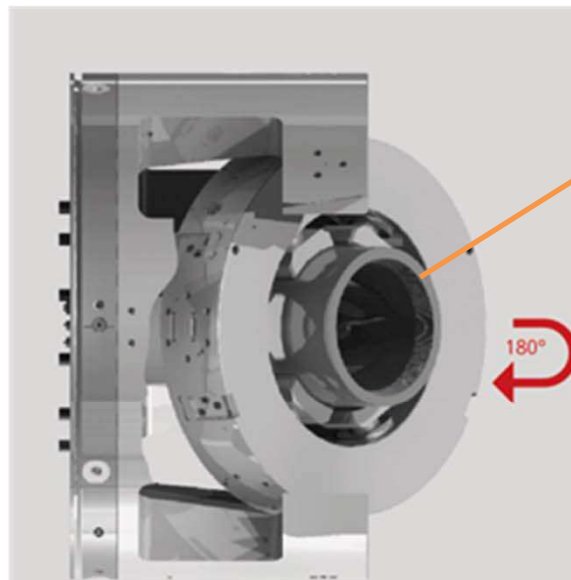

Fig. 2
Indexing the chuck 180° with the coupling remaining clamped.



Fig. 3
After indexing 180° machining the thread on side 2.